

### STANDARD SIZES

PART	MIN DIM.	MAX DIM.
A	48"	60"
B	35"	60"
C	17"	17"

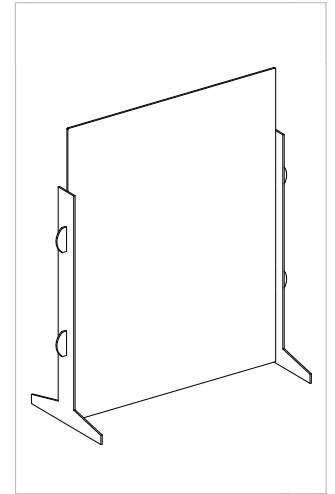
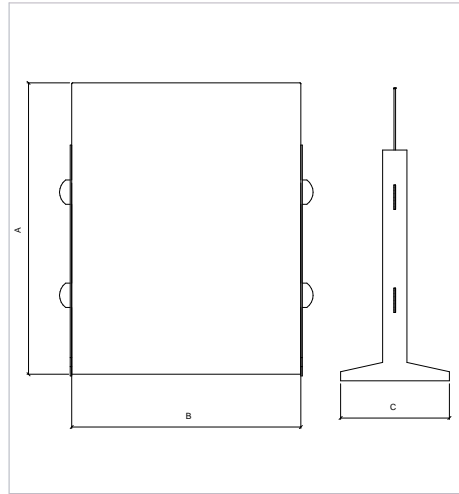

### SPECIFICATION

Free Standing Screen - Solid Design shall be Model **FSFS-173548C38E0-00**, 48" (1219mm) High x 35" (889mm) Wide x 17" (432mm) Deep, made of Trespa Toplab Base, double-sided 1/4" (6mm) screen, designed for easy mounting with 3/8" (10mm) freestanding feet. Easy 'click' assembly with no tools required. Standard color shall be Trespa E0-00 white. Tested to SEFA 3 (horizontal surfaces) and SEFA 8 (vertical surfaces) for chemical resistance. 10-year conditional warranty. Manufactured by Spectrum Lockers. (spectrumlockers.com)

### MATERIALS

Free Standing Screen - Solid Design, 1/4" (6mm) and 3/8" (10mm) thick Trespa Toplab Base, laboratory grade, high pressure compact laminate, fabricated with natural fibres and thermosetting resins, Greenguard Gold Certified. Trespa International B.V. is a member of SEFA (Scientific Equipment and Furniture Association) and VIP3000 (Association for Cleanrooms and Pharmaceutical Construction). Excellent resistance to most aggressive chemicals and cleaning agents.

Weight: Approximately 80lb.

### ASSEMBLY & OPERATION

Easy click assembly with no tools required. Designed for easy mounting with free standing feet.

### OPTIONS

- Trespa TopLab Vertical - with Patented Electron Beam Cured (EBC) technology. Does not support bacterial growth.
- Non-Standard Color: \_\_\_\_\_
- Custom Dimensions: \_\_\_\_\_ Height x \_\_\_\_\_ Width x \_\_\_\_\_ Depth

### VARIOUS SAFETY SCREENING PRODUCTS

View the complete collections: [www.spectrumlockers.com](http://www.spectrumlockers.com)