

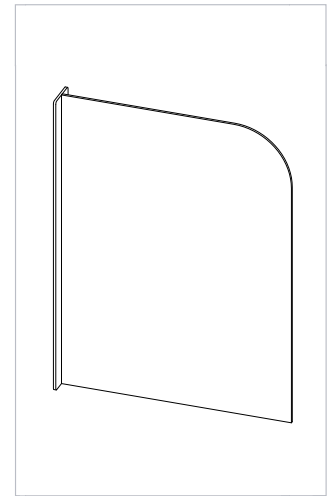

STANDARD SIZES

PART	MIN DIM.	MAX DIM.
A	32"	32"
B	24"	24"
C	3 1/2"	3 1/2"

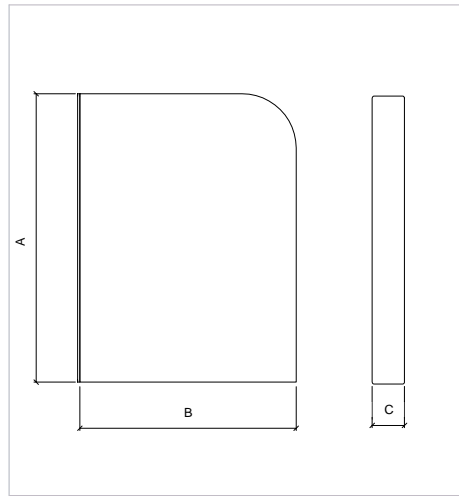

SPECIFICATION

Sink Divider Safe Screen shall be Model **SDS1-2432F38E0-00**, 24" (610mm) Deep x 32" (813mm) High with 3 1/2" (89mm) base, made entirely of 3/8" (10mm) Trespa Toplab Base, double-sided, designed for easy mounting with freestanding feet. Some assembly required. Standard color shall be Trespa E0-00 white. Tested to SEFA 3 (horizontal surfaces) and SEFA 8 (vertical surfaces) for chemical resistance. 10-year conditional warranty. Manufactured by Spectrum Lockers. (spectrumlockers.com)

MATERIALS

Sink Divider Safe Screen, Free Standing, 3/8" (10mm) thick Trespa Toplab Base, laboratory grade, high pressure compact laminate, fabricated with natural fibres and thermosetting resins, Greenguard Gold Certified. Trespa International B.V. is a member of SEFA (Scientific Equipment and Furniture Association and VIP3000 (Association for Cleanrooms and Pharmaceutical Construction). Excellent resistance to most aggressive chemicals and cleaning agents. Weight: Approximately 10lb.

ASSEMBLY & OPERATION

Panel to be fastened to base, fasteners to be provided. Base to be fastened to wall, fasteners not provided to be provided by installer as required.

OPTIONS

- Trespa TopLab Vertical - with Patented Electron Beam Cured (EBC) technology. Does not support bacterial growth.
- Non-Standard Color: _____
- Custom Dimensions: _____ Height x _____ Width x _____ Depth

VARIOUS SAFETY SCREENING PRODUCTS

View the complete collections: www.spectrumlockers.com